



User Manual PCIe x4 Gen2 Switch-based Cable Adapter OSS-PCIe-HIB35-x4



www.onestopsystems.com

Phone 877-438-2724 • Fax 760-466-1678 • sales@onestopsystems.com

Table of Contents

1. Overview

1.a. Board Description.....	3
1.a.1 Network Adapter.....	3
1.a.2 I/O adapter	3

2. Components

2.a. Host interface board.....	4
2.b. Block diagram.....	4
2.c. Cable adapter specifications	5
2.d. Switch description	5

3. Installation Instructions

3.a. Connecting the PCIe cable.....	6
3.b. Removing the PCIe cable.....	6

4. Technical Information

4.a. Dip switch configurations.....	7
4.b. Appendix A	8
4.c. Signal Descriptions	8

4. Ordering Information

1. Overview

1.a. Board Description

The switch-based is PCIe x4 cable adapter can be used in two modes; as a network adapter between two systems and as an I/O adapter between a host system and a downstream I/O device.

1.a.1

Network adapter

The switch-based cable adapter can be configured to operate in upstream and downstream modes when cabled between two processors. The main function of the switch-based board is to:

- 1) isolate the spread spectrum clock that is transmitted from both processors, and
- 2) allow memory transfers from one processor's memory to the other's memory

When used in this architecture, it is assumed that the customer is writing a specific driver for his application or using the ExpressNet 2.0 driver installed on both systems.

1.a.2

I/O adapter

The switch-based adapter can also be used in a host system cabled to a downstream I/O device in applications where noise from the host system must be isolated from the downstream appliance by the switch.

Note: See the factory for the availability of the ExpressNet 2.0 driver.

Note: The clock on the switch-based adapter is set at 100.3 Mhz due to a PCIe specification requirement that states that in order to isolate spread spectrum, the clock between the two systems must be set to higher than the anticipated jitter of the 100mhz clock. Therefore, if the application is to operate the HIB35x4 from a host system to a downstream device that emits its own clock, a downstream HIB35x4 must also be used.

2. Components

2.a. Host Interface Board

The PCIe x4 Gen 2 host cable adapter that allows PC to PC communication when used with another HIB-35 and the ExpressNet driver. It includes PCIe 8-lane switch including NT port (non-transparent) and built-in DMA controller.

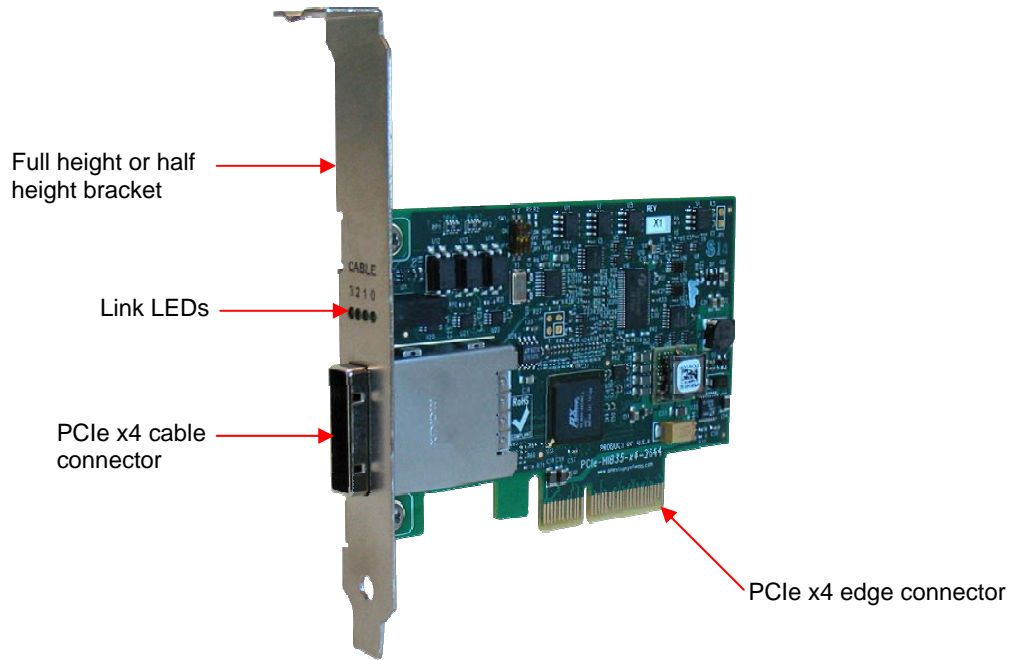

2.b. Block diagram

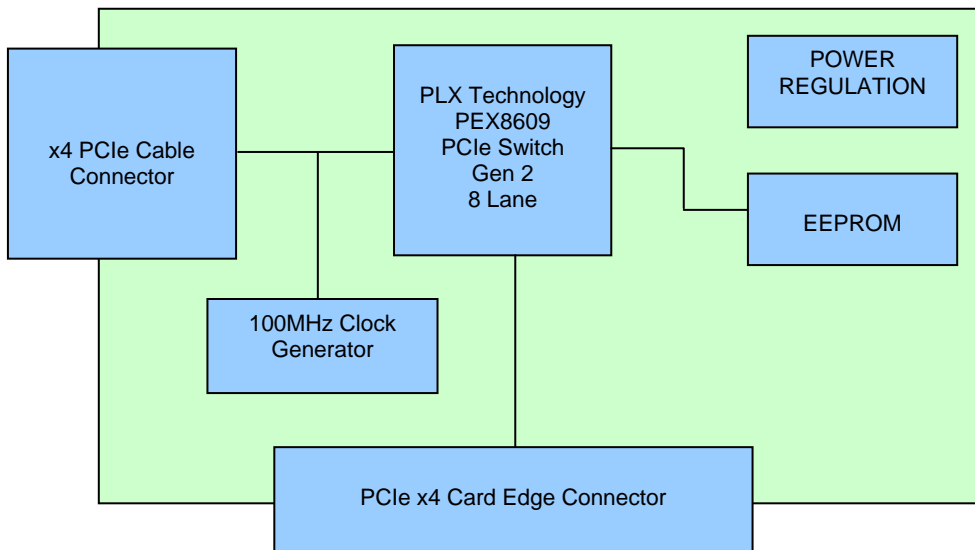

2.c. Cable adapter specifications

Form Factor	PCIe low profile
Operating Temperature	0°C to +50°C environment
Storage Temperature	-40°C to 85°C
Operating Humidity	10% to 90% relative humidity non-condensing
Storage Humidity	5% to 95% relative humidity non-condensing
Power	0.4A @ 12V
Connectors	<ul style="list-style-type: none">• PCIe x4 cable connector• PCIe x4 edge connector
Industry Specifications	<ul style="list-style-type: none">• PCIe External Cabling Specification, Rev. 1.0• PCI Express™ Card Electromechanical Specification, Rev. 2.0• PCI Express® Base Specification, Rev. 2.0
PCB	<ul style="list-style-type: none">• PCI Express add-in card standard• x4 PCIe cable to front panel
PCIe Switch	<ul style="list-style-type: none">• 5.0 Gbps 4-Lane PCI Express Gen 2
Bracket	<ul style="list-style-type: none">• Standard and low profile brackets available• Cable connection LED
Agency Compliance	Pending: <ul style="list-style-type: none">• FCC Class B• CE

2.d. Switch Description

8 Lane, 8 Port PCI Express Switch, 15 x 15mm PBGA

The ExpressLane™ PEX 8609 offers 8 PCI Express Gen 2 (5.0 GT/s) lanes, capable of configuring up to 8 flexible ports and fully conforms to the PCI Express Base Specification, rev 2.0. PEX 8609 architecture supports a high-performance DMA engine with four DMA channels and internal buffer space for internal descriptor support. Up to 256 descriptors are supported internally or alternatively descriptors can also exist in host memory. Each descriptor provides support for large transfer sizes (up to 128MB) giving the user the capability to perform very large data transfers in any direction (memory to device, device to device, memory to memory). PEX 8609 also supports cut-thru with the industry's lowest latency of 140ns (x4 to x1) and offers two virtual channels for traffic prioritization in the system. The device also features an on-chip Non-Transparent port for dual-host and failover applications and supports dual-clock domain operation by virtue of support for Spread Spectrum Clock (SSC) isolation, is offered in a 15 x 15mm 324-ball PBGA and is available in both leaded and lead-free packaging. This device supports Access Control Services (ACS).

3. Installation Instructions

3.a. Connecting the PCIe cable

1) Firmly insert the cable connector into the board cable connector shell. The teeth on the cable connector shell MUST engage completely in the holes on the board connector shell. Always check the connection if link problems are exhibited.

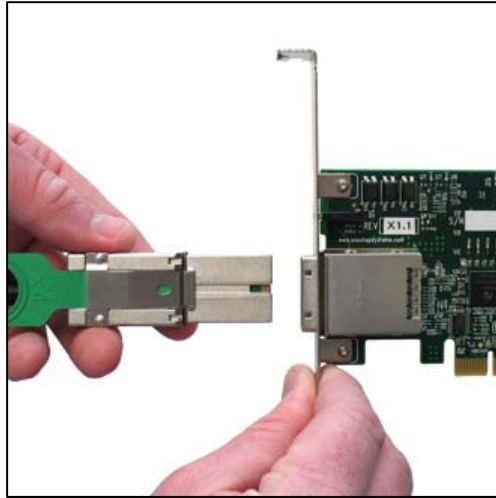

3.b. Removing the PCIe cable:

1) Pull back on the green thumb tab to release the metal teeth and pull the cable connector out of the board connector shell.

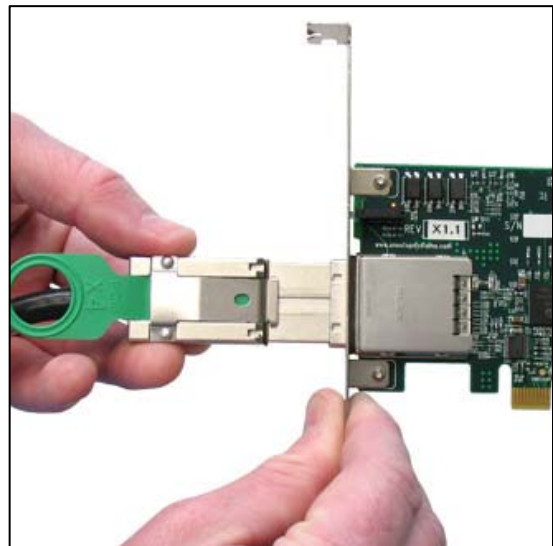
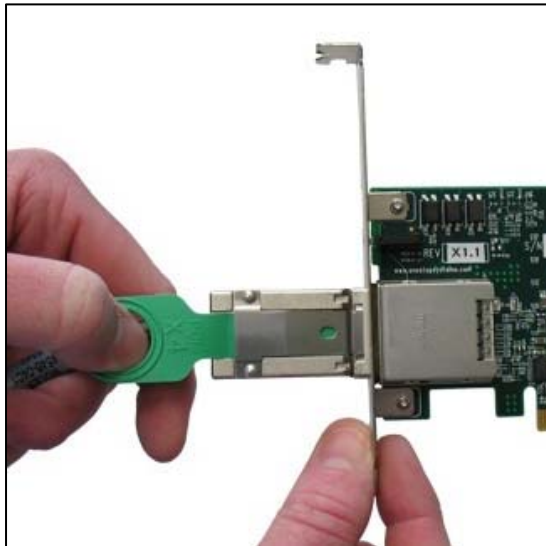

4. Technical Information

4.a. Dip switch configurations

The following dip switch configurations are required for proper board operation in network and I/O architectures.

To operate the boards in a network scheme, the dip switches of the two boards must be set in option A (Host) and option B (Target) configurations.

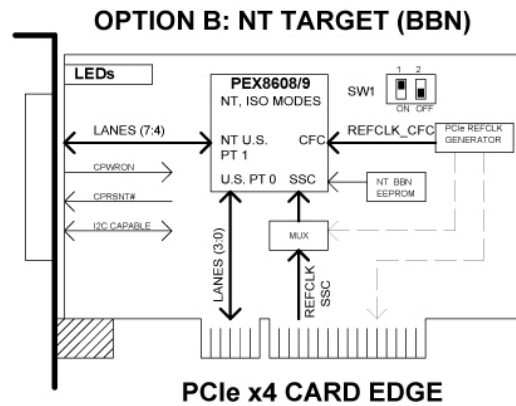
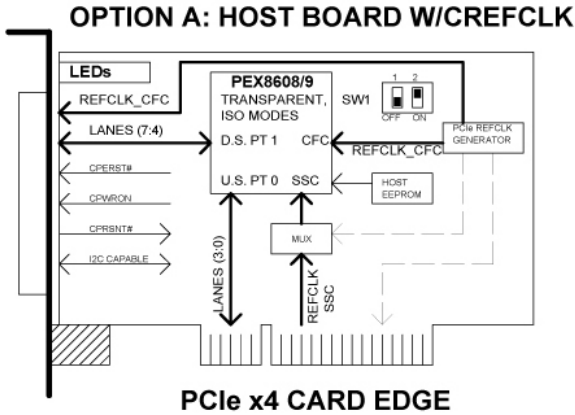

To operate the boards in an I/O scheme, the dip switches must be set in option A (Host) and option C (Target) configurations.

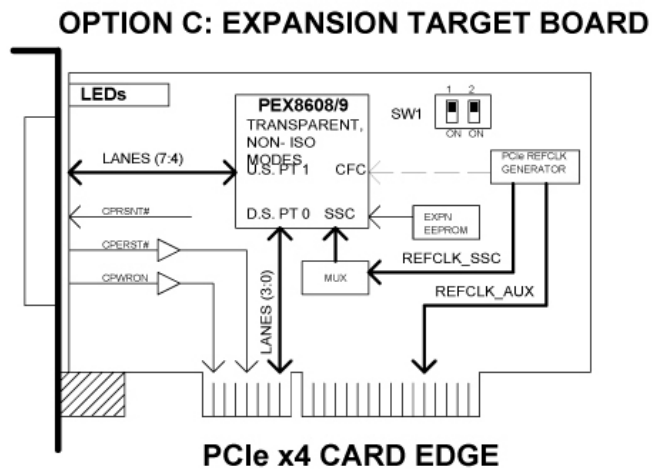

The following diagrams show the dip switch settings more visibly:

OPTION A



OPTION B



OPTION C



OPTION D



NOTE: Option D is a factory setting and is not for user configuration

4.b. Appendix A

Pin out for PCIe x4 cable connector

Pin #	Cable Side 1		Cable Side 2	Pin #
A1 A4 A7 A10 A13 A16 B1 B4 B7 B10 B13	GND	Drain Wires	GND	A1 A4 A7 A10 A13 A16 B1 B4 B7 B10 B13
A2	PETp0	Differential Pair	PERp0	B2
A3	PETn0		PERn0	B3
A5	PETp1	Differential Pair	PERp1	B5
A6	PETn1		PERn1	B6

Pin #	Cable Side 1		Cable Side 2	Pin #
A8	PETp2	Differential Pair	PERp2	B8
A9	PETn2		PERn2	B9
A11	PETp3	Differential Pair	PERp3	B11
A12	PETn3		PERn3	B12
A14	CREFLCK+	Differential Pair	CREFLCK+	A14
A15	CREFLCK		CREFLCK-	A15
A17	SB_RTN	Hook-up Wire	SB_RTN	A17
A18	CPRSNT#	Hook-up Wire	CPRSNT#	A18
A19	CPWRON	Hook-up Wire	CPWRON	A19
B2	PERp0	Differential Pair	PETp0	A2
B3	PERn0		PETn0	A3
B5	PERp1	Differential Pair	PETp1	A5
B6	PERn1		PETn1	A6
B8	PERp2	Differential Pair	PETp2	A8
B9	PERn2		PETn2	A9
B11	PERp3	Differential Pair	PETp3	A11
B12	PERn3		PETn3	A12
B14	PWR	NC	PWR	B14
B15	PWR	NC	PWR	B15
B16	PWR_RTN	NC	PWR_RTN	B16
B17	PWR_RTN	NC	PWR_RTN	B17
B18	CWAKE#	Hook-up Wire	CWAKE#	B18
B19	CPERST#	Hook-up Wire	CPERST#	B19
Backshell	Chassis Ground	Overall Cable Braid	Chassis Ground	Backshell

4.c. Signal Descriptions

PETp(x)	PCI Express Transmit Positive signal of (x) pair.
PETn(x)	PCI Express Transmit Negative signal of (x) pair.
PERp(x)	PCI Express Receive Positive signal of (x) pair.
PERn(x)	PCI Express Receive Negative signal of (x) pair.
CREFLCK+/-	Cable REFerence CLock: Provides a reference clock from the host system to the remote system.
SB_RTN	Side Band ReTurN: return path for single ended signals from remote systems.
CPRSNT#	Cable PReSeNT: Indicates the presence of a device beyond the cable.
PWR	PoWeR: Provides local power for in-cable redriver circuits. Only needed on long cables. <small>Power does not go across the cable.</small>
PWR_RTN	PoWeR ReTurN: Provides local power return path for PWR pins.
CWAKE#	Cable WAKE
CPERST#	Cable PCI Express Reset

5. Ordering Information

OSS-PCIe-HIB35-x4 - PCIe Gen 2 Host Interface Board (HIB) with the full height bracket

OSS-PCIe-HIB35-x4 - Half height bracket

Related Products

OSS-PCIe-HIB25-x4-H - PCIe x4 Gen 2 host cable adapter installs in a x4, x8, or x16 expansion slot of a host system to extend the host PCIe bus to an expansion system or PCIe device.

OSS-PCIe-HIB25-x4-T - PCIe x4 GEN 2 target cable adapter is only used with the OSS 2-slot PCIe backplane to add a single PCIe card to a host.

OSS-SHB-ELB-x4/x8-2.0 - PCIe x8 or x4 Gen 2 expansion link board installs in SHBe slot of a PCIe Gen 2 back plane, allowing either x8 or x4 cable inputs from upstream host system.

OSS-PCIe-CBL-x4-2M - 2 meter PCIe x4 cable with PCIe x4 connectors.