

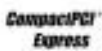

PCI Downstream Express Cable Adapter

PCIe-HIB4 x 4



www.onestopsystems.com

Phone 877-438-2724 • Fax 760-466-1678 • sales@onestopsystems.com

Unpacking Instructions

1. If the carton is damaged when you receive it, request that the carrier's agent be present when you unpack and inspect the equipment.
2. After unpacking, verify that all items listed in the packing list are present.
3. Inspect the equipment for shipping damage.
4. Save all packing material for storage or return shipment of the equipment.
5. For repairs or replacement of equipment damaged during shipment, contact One Stop Systems, Inc. to obtain a Return Materials Authorization (RMA) number and further shipping instructions.

Installation and Removal

1. Power down the system.
2. Open the chassis according to your system documentation.
3. Let the power supply cool down, if necessary.
4. Remove the Target Cable Adapter from the protective bag, observing proper ESD safety procedures.

Installing the Target Cable Adapter:

1. Insert the Target Cable Adapter into a PCIe x4, x8 or x16 add-in card slot¹. Make sure that the card is well seated, and tighten the screw.
2. Attach the cable by first pulling back on the retractor ring. With the keyed slot aligned with the key ridge of the Target Cable Adapter slot cover, insert the cable connector into the cable port connector on the board until the cable locks in place.
3. The connectors on either end of the PCIe x4 cable are identical. Each connector is equipped with a retractor to allow the connector to be locked into place.

Retractor on Cable Connector

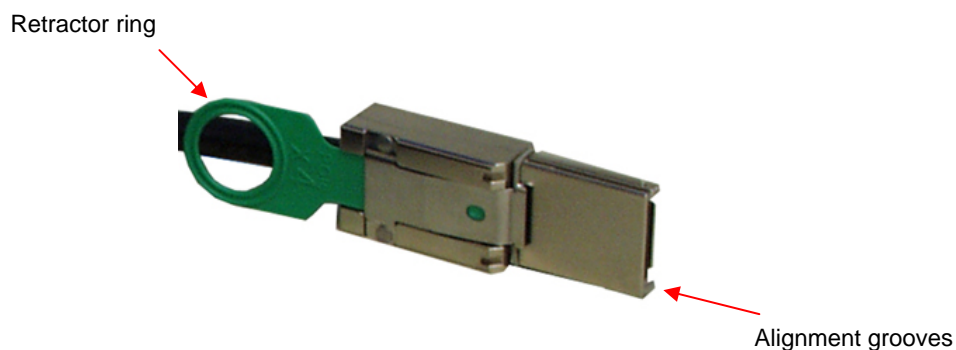

4. Attach the other end of the cable to the cable port connector of the HIB2, HIB5, or PCI Express switch depending on your SuperSwitch configuration.

¹ "Up-plugging" the Target Cable Adapter into a x8 or x16 slot is allowed, but the motherboard manufacture may limit the bandwidth to x1 (250MB/s) speeds. If you need to do this, check with the motherboard manufacturer to see how up-plugging is handled on their motherboards. A PCIe x4 board will not physically fit in a x1 slot.

Removing the Target Cable Adapter:

1. Remove the cable by pulling on the green retractor ring which releases the locking mechanism.
2. Loosen and remove the screw before removing the Target Cable Adapter from the card slot.

Description

The Target Cable Adapter (Part # OSS-PCIe-Target Cable Adapter-x4) provides the target-side link for peripheral CPUs in SuperSwitch Configurations. It is a low profile PCI express (PCIe) card that connects to a host interface board, or PCIe switch through a PCIe x4 cable.

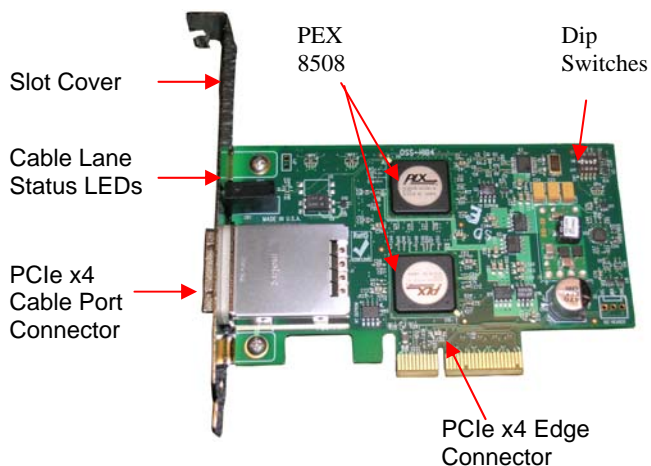

Specifications

Electrical/Mechanical Specifications	
Form Factor:	PCIe x4 add-in card
Dimensions (H x L):	2.713 x 4.395 inches (68.9 x 111.6mm)
Front Panel Connectors:	One PCIe x4 cable connector
Front Panel Indicators:	Cable Lane Status LEDs
Power Consumption (designed to meet the following conditions)	
	6.5W maximum, 12V@ .4A and 3.3V@ .45A
Operating Environment (designed to meet the following conditions)	
Temperature Range:	0° to 50°C (32° to 122°F)
Relative Humidity:	10 to 90% non-condensing
Shock:	30g acceleration peak (11ms pulse)
Vibration:	5-17 Hz 0.5" double amplitude displacement; 7-2000Hz, 1.5g acceleration.
PCI Express Switches	
PLX PEX8508	
Agency Compliance Designed to meet, but not tested	
	UL60950, FCC Class B, CE safety and emissions

Dimensions

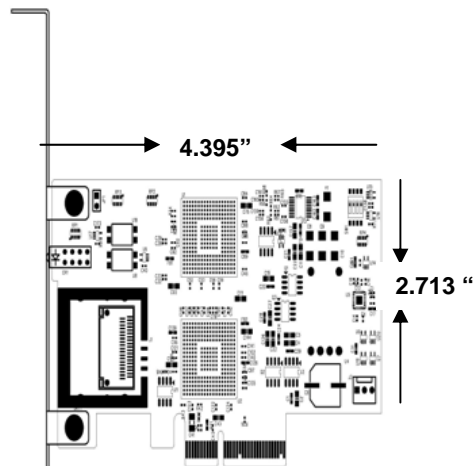

Block Diagram

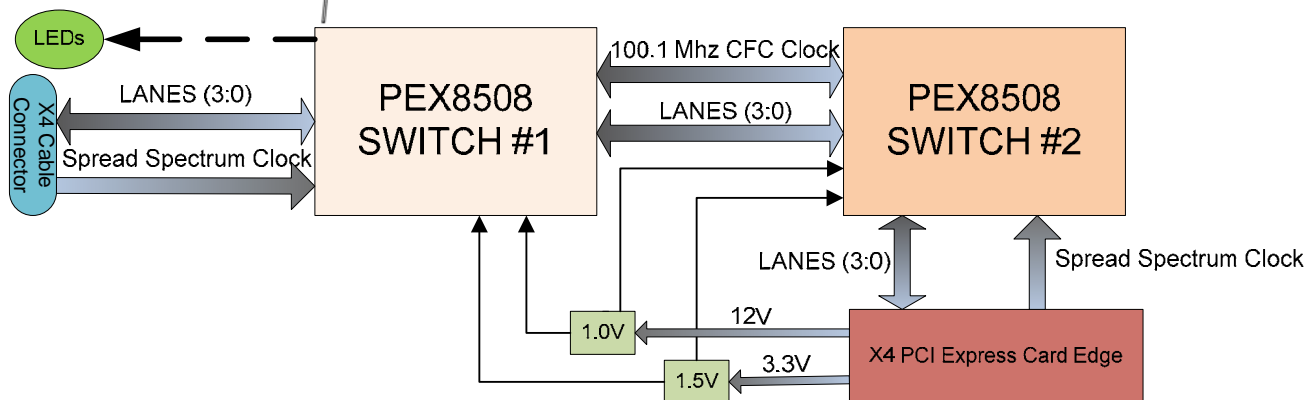

Spread Spectrum Clocking

Spread Spectrum Clocking is a method of varying the clock frequency to reduce EMI by spreading noise emissions across a broad spectrum of frequencies. The required PCI Express method is to modulate the clock frequency in a manner that does not allow the clock frequency to go higher than the nominal frequency.

In a SuperSwitch system, processors are connected using a non-transparent bridge. In a non-transparent bridge, both sides of the bridge (Host and Target) have the potential to use individual Spread Spectrum Clocks. However, the modulated clocks on either side of the bridge are not in sync with each other and could cause data to be lost.

To allow the use of Spread Spectrum Clocking on both sides of the bridge, the Target Cable Adapter uses two 8508 switch chips. These chips support "Dual Clocking Mode" which allows the chip to transmit and receive two PCIe clocks simultaneously. A constant frequency clock is established between the two switch chips using one of the PCI Clock lines on each of the chips, and the other clock line on each chip accepts a Spread Spectrum Clock from either the Host or Target. This setup allows both systems to use Spread Spectrum Clocking.

Switches

The Target Cable Adapter contains one x4 dip switch. See Spread Spectrum Clocking section for an explanation of how the Target Cable Adapter handles Spread Spectrum Clocking when SW1-1 is ON. See for details on the switch settings.

SW1	Description	ExpressNet	Settings
1	Spread Spectrum Clock Support	ON	OFF = Single Clock Mode ON = Dual Clock Mode
2	8508 #2 NT Mode Select	OFF	OFF = Dual Host Mode ON = Intelligent Adapter Mode
3	EEPROM #1 Present	OFF	OFF = EEPROM not present ON = EEPROM is present
4	EEPROM #2 Present	ON	OFF = EEPROM not present ON = EEPROM is present

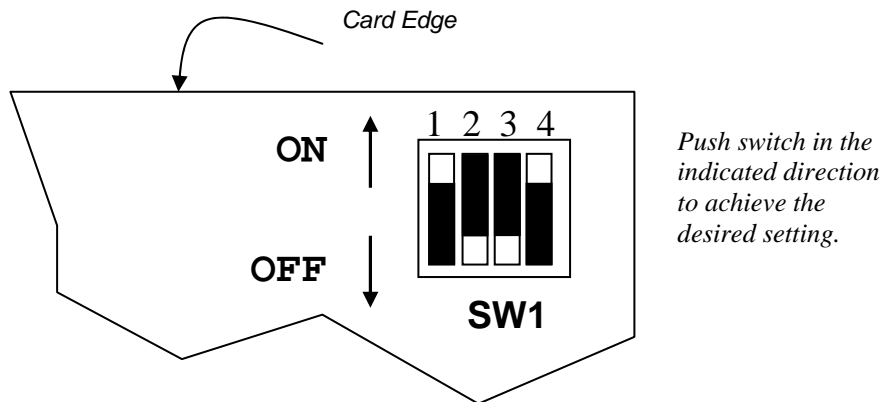

LEDs

See below for details on the interpretation of the LEDs.

CR1: 1x4 Quad LED on front panel indicates Lane Good Status for each of the four PCIe lanes on the cable. The lanes are labeled 0-3.

CR2-CR11: Individual LEDs on the BACK SIDE of the Target Cable Adapter PCB. The figure below shows the locations, order and placement of the LEDs on the board.

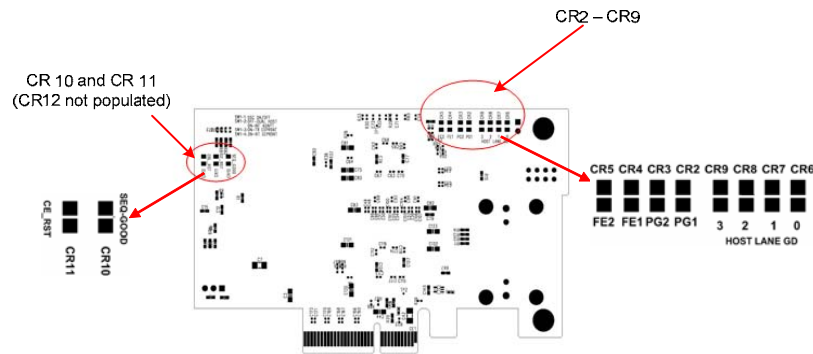

LED #	PCB Label	Function	Description
CR2	PG1	Internal port good indicator for lane on 8508 PCIe switch #1	When lit, these two LEDs indicate a good PCIe lane connection between the two switches
CR3	PG2	Internal port good indicator for lane on 8508 PCIe switch #2	
CR4	FE1	Fatal error indicator for PCIe switch #1	When lit these two LEDs indicate an internal Fatal Error signal from the switch
CR5	FE2	Fatal error indicator for PCIe switch #2	
CR6	0	PCIe lane status on the card edge for lane 0	These four LEDs are labeled together as "HOST LANE GD" below the individual numbers, and indicate a valid signal level on the appropriate PCIe lane of the Card Edge.
CR7	1	PCIe lane status on the card edge for lane 1	
CR8	2	PCIe lane status on the card edge for lane 2	
CR9	3	PCIe lane status on the card edge for lane 3	
CR10	SEQ_GOOD	Power Good indicator for board	
CR11	CE_RST	Card Edge PCIe reset	

Connectors

The Target Cable Adapter has two connectors on it:

1. **PCIe X4 Card Edge Connector** per *PCI Express Card Electromechanical Specification Revision 1.1 (March 28, 2005)*
2. **PCIe X4 Cable connector** per *PCI Express External Cabling Specification Revision 1.0 (January 4, 2007)*

Addendum A - ExpressNet Linux Driver²

Description

The ExpressNet software package for Linux consists of three major components and their associated include and make files.

- The kernel driver
- A user library
- A demonstration/performance testing program

These are all supplied as source files written in C and packaged in a compressed tar file **expressnettar.bz2**, provided on a CD with your Target Cable Adapter.

Requirements

64-bit version of Linux, with Linux kernel version 2.6.20 or greater running on a 64-bit AMD or Intel CPU. However, ExpressNet may work in simple configurations with earlier versions and/or 32-bit versions of Linux. Kernel module dependencies are documented in the *html/readme.html* file contained on the CD.

Extraction

The files in the **expressnettar.bz2** file all untar into the **opt/ossi/expressnet** directory tree. For most Linux system, to untar it into the standard location, /, you must log in as **root** and execute:

```
cd /; tar xvfj directory_path/expressnettar.bz2
```

In the resulting **opt/ossi/expressnet** directory you will find:

Applications	The directory containing the ExpressNet demonstration program.
Documentation	The directory containing documents not found in the html or manpages directory.
Driver	The directory containing the ExpressNet Linux driver.
file list	A list of all ExpressNet files installed in the system that is used to uninstall ExpressNet.
Html	The directory containing ExpressNet documentation in web format.
Include	The directory containing the ExpressNet include files.
init.d	The directory containing the script which enables the system to control the loading of the driver.
Lib	The directory containing the ExpressNet library files.
Manpages	The directory containing ExpressNet documentation in manpage format.
Pexload	The directory containing the ExpressNet EEPROM programming utility.
INSTALL	A shell script that compiles and installs the driver and library and compiles the demonstration program.
UNINSTALL	A perl script that removes all ExpressNet files on the system.

² The following information was correct at the time this manual was published. Please read the readme.html on the CD for the most up to date requirements and installation procedures.

Driver Installation

Follow the explanations and instructions in the README documentation in the HTML directory.

Licensing Agreement

This program is free software; you can redistribute it and/or modify it under the terms of the GNU General Public License version 3, or (at your option) any later version.

This program is distributed in the hope that it will be useful, but WITHOUT ANY WARRANTY; without even the implied warranty of MERCHANTABILITY or FITNESS FOR A PARTICULAR PURPOSE. See the GNU General Public License for more details. A copy of this license can be found in **documentation/gpl.txt** on the CD.

Addendum B – SuperSwitch Configurations

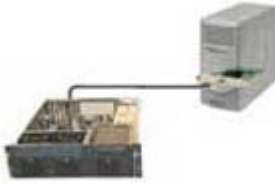

SuperSwitch 1 PCI Express-over-cable solutions for point-to-point communications

- SuperSwitch 1 includes one PCIe x4 host adapter attached via a PCIe x4 cable to a CPCI Express x4 cable adapter,
- PCIe x4 cable adapter or Express Card and ExpressNet software suite.
- Data transfers between two systems occur at 20Gb/s.
- ExpressNet software supports 64 bit CPUs as well as multithreaded environments.
- PCIe cables in 1m, 2m, 3m, 5m and 7m lengths.

Part #: OSS-SS1-X-XM

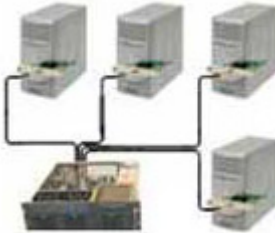

SuperSwitch 2 PCI Express-over-cable networking for 3 to 5 PCs

- SuperSwitch 2 includes connecting up to five processors using one PCIe x4 mezzanine cable adapter, up to four PCIe x4 cable adapters, PCIe cables up to 7 meters and ExpressNet software suite.
- Enables data transfers at speeds up to 20Gb/s.
- ExpressNet software supports 64 bit CPUs as well as multithreaded environments.
- PCIe cables in 1m, 2m, 3m, 5m and 7m lengths.

Part #: OSS-SS2-X-XM



SuperSwitch 3 PCI Express-over-cable networking for 6 to 8 PCs

- SuperSwitch 3 includes connecting up to eight CPUs or any combination of CPUs and I/O devices, using one 8-port 1U switch, one PCIe x4 host adapter, Express Card or CPCIe host adapter, up to 7 PCIe host cable adapters, up to 8
- PCIe cables and ExpressNet software suite.
- Enables data transfers at speeds up to 20Gb/s.
- ExpressNet software supports 64 bit CPUs as well as multithreaded environments.

Part #: OSS-SS3-X-XM

Addendum C – Switch and LED technical reference guide

Switches

Switch SW1-1 Spread Spectrum Clock: ExpressNet is not dependant upon either Single or Dual Clock Modes; it is PCIe Link negotiation and data recovery in association with PEX8508 clock recovery that governs subsequent Link operability. SW1-1 should be set ON to enable Dual Clock Mode and Spread Spectrum Clock support. Single Clock Mode (SW1-1 OFF) is for testing purposes only. For more information, read the *Spread Spectrum Clocking* section on page 4.

Switch SW1-2 NT Mode Select: ExpressNet usage requires that PEX8508 #2 utilize *Dual-Host Mode* (SW2-2 OFF). In a Dual-Host application, the PEX8508 is used to isolate the two hosts, by routing traffic through the NT Port by way of two x4 links. Intelligent Adapter Mode (SW2-2 ON) is NOT applicable to ExpressNet operation via PEX8508 #2.

Note that PEX8508 #1 is hardwired for *Transparent Mode*.

EEPROM Usage: The optional EEPROMs are used to initialize the PEX8508 registers for ExpressNet usage. The current ExpressNet Driver software uses unique, EEPROM information supplied to PEX8508 Chip #2, but uses all Default register values from PEX8508 Chip #1. This requires that the EEPROM for Chip #2 be Enabled (ON), and the EEPROM for Chip #1 be Disabled (OFF). Read more under Switch SW1-3 and Switch SW1-4, below.

Both EEPROM's can be reprogrammed in the field for special needs by following the supplied ExpressNet documentation or directions from customer support

Switch SW1-3 & EEPROM #1 Contents: The contents of this EEPROM are blank or the EEPROM is not populated. The default PEX8508 values for PEX8508 Chip #1 are required for ExpressNet usage and, therefore, it is mandatory to set SW1-3 to OFF to disable EEPROM #1.

Switch SW1-4 & EEPROM #2 Contents: This EEPROM supplies the board's unique Serial Number to the ExpressNet Driver, which uses the number in formulating a MAC address. Additional Manufacturing information is also contained in EEPROM #2. The EEPROM settings also disable unused BARs, Devices and Links within the PEX8508. Though the ExpressNet Driver is still fully functional when EEPROM #2 loads Default values instead of EEPROM values, it is recommended to set SW1-4 to ON to enable EEPROM #2 usage.

Default values will also be loaded if the PEX80508 discovers that its EEPROM contents are corrupted (CRC mismatch).

LEDs

LED Usage: CR1 Front Panel Lane Good Status [green]. If the HIB4 board's cable is plugged into an HIB2, for example, it should then have all four Lane LEDs lit, signifying correct x4 operation (this assumes that the HIB2 is itself powered up!). If only 0 is set, this signifies only x1 Lane operation. The system will continue to perform normally with x1 Lane Width, but with lower throughput due to the lesser number of PCIe lanes available. **Having 2 or 3 Lane Good LEDs lit is an abnormal condition.**

LED Usage: CR2/3 Port Good [green]. Both of these LEDs must be lit for correct operation. They should be lit regardless of whether either end of the cable is connected, and regardless of the state of any hardware connected to the far end of the cable. If they are not lit, it indicates that a PCI Express link was not established between the two PEX8508 chips and communications between the two cannot occur.

LED Usage: CR4/5 Fatal Error [red]. These LEDs should never be lit as they indicate a PEX8508 internally detected error. Contact OSSI Customer Service for further assistance.

LED Usage: CR6,7,8,9 Host Lane Good Status [green]. The HIB4 board should have all four Lane LEDs lit, signifying correct x4 operation. Having 1 Lane Good LED lit (CR6) is operational, but indicates x1 operation. (See note on up-plugging in installation section) Having 2 or 3 Lane Good LEDs lit is abnormal. Blinking LEDs signify the Lanes are going up and down, a bad situation. Ensure that Switch SW1-1 is ON, allowing Spread Spectrum support. Alternately, attempt to disable Spread Spectrum Clocking from within your system's BIOS to test whether you might be encountering an out-of-bound Spread Spectrum clock from the system's PCIe bus.

LED Usage: CR10 SEQ_GOOD [green]. This LED is lit by detection of the +3.3V level and should always be lit once power is stable.

LED Usage: CR11 CE_RST [red]. This LED is lit only when the board is in a reset state. BIOS and PCIe bus resets can cause this LED to blink. This is an informational LED only.

LED Usage: CR12 CBL_RST [red]. This LED is not connected and/or not populated. The capability to monitor the reset signal driven from the upstream end of the cable is reserved for future use.