

## User Manual, Host server to expansion system kit (OSS-KIT-EXP-500)

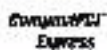

# Table of Contents

## 1. Overview

1.a. Description .....	3
1.b. Conceptual Architecture .....	3

## 2. Component Identification

2.a. Express card .....	4
2.b. Target cable adapter .....	4
2.c. Express card specifications .....	5
2.d. Target adapter specifications .....	5
2.e. OSS 2-slot backplane.....	6

## 3. Installation Instructions

3.a. Installing the adapter kit .....	7
3.b. When using 2-slot backplane .....	7
3.c. When using with any third party I/O device .....	8
3.d. Removing PCIe cable.....	8
3.e. Removing your express card cable adapter .....	8

## 4. Technical Information

4.a. Redriver settings .....	9
4.b. Host cable adapter LEDs .....	9
4.c. Pin assignments .....	10
4.d. PCI Express x4 Connector Pin Assignment .....	11
4.e. Pin-out for PCIe x4 cable .....	12
4.f. Signal descriptions .....	13

## 5. Ordering Information

### 1.a. Description

The PCIe x4 express card fits into the expansion slot of a host laptop computer. It then cables to a downstream target adapter via a PCIe adapter cable. The target adapter then inserts into a 2-slot backplane in the target enclosure.

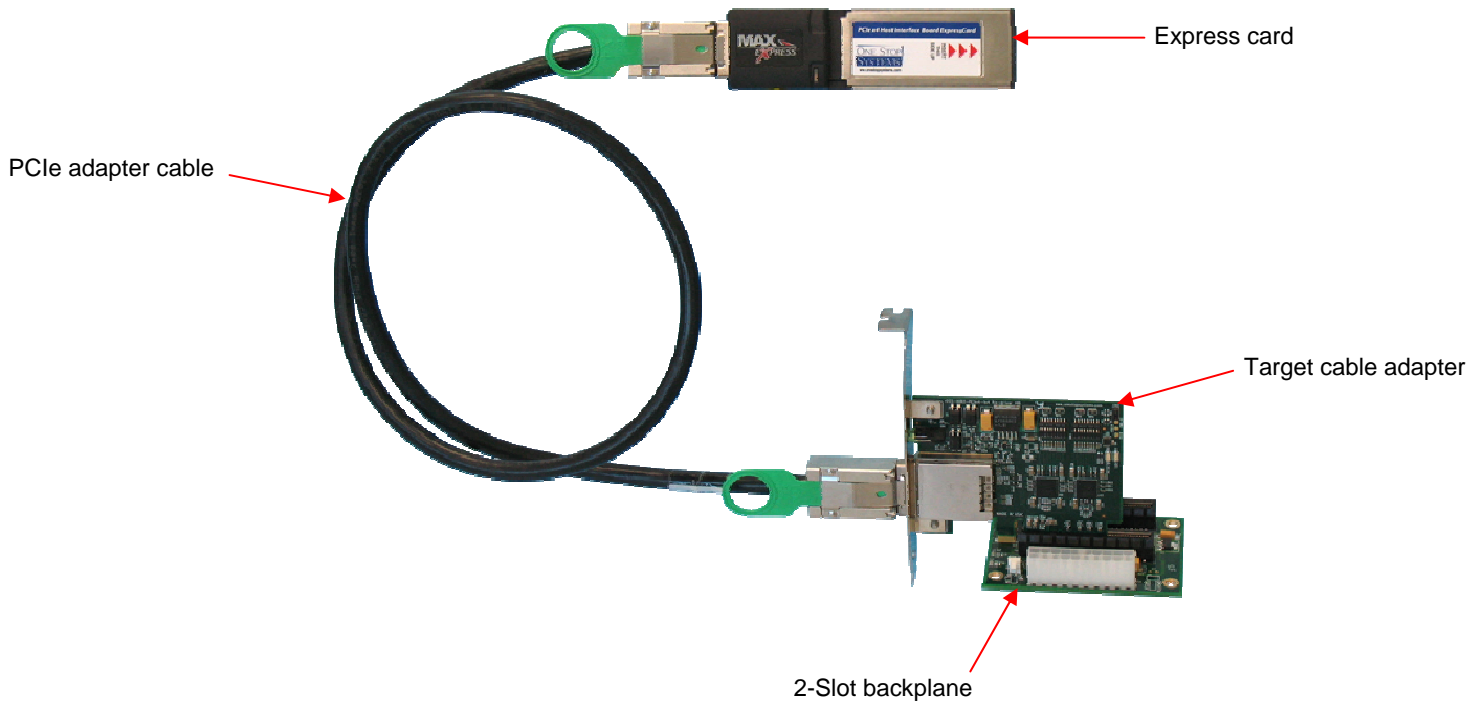

### 1.b. Conceptual architecture

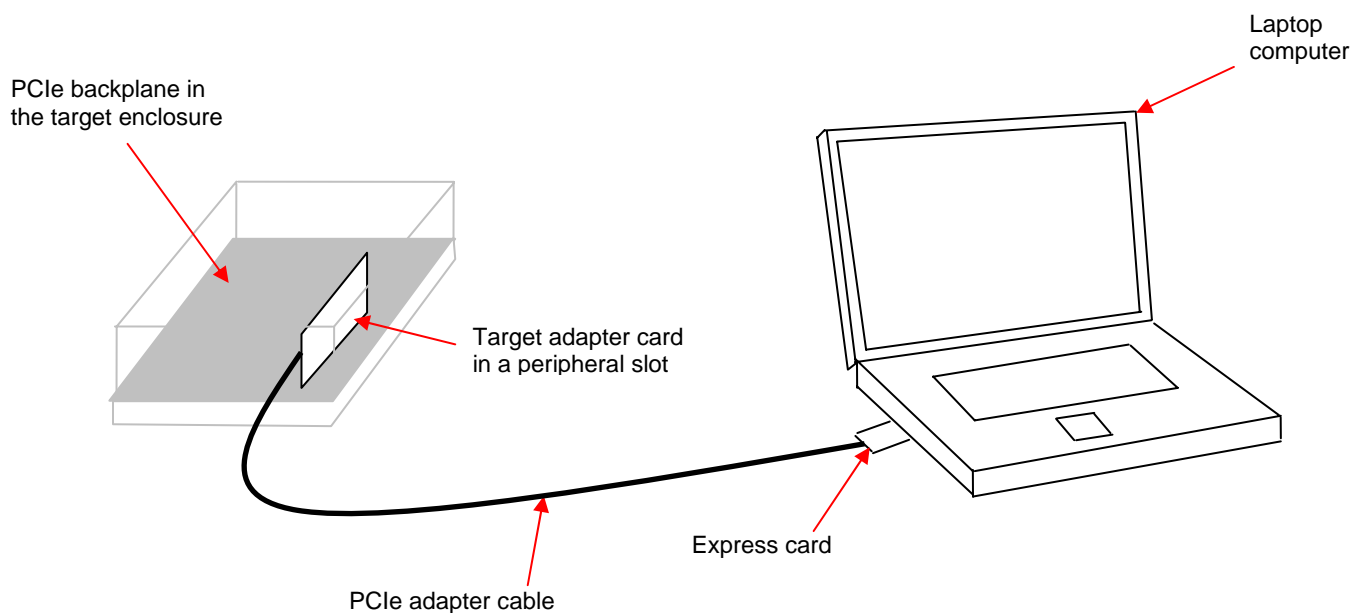

## 2. Component Identification

### 2.a. Express card

The ExpressCard cable adapter (OSS-PCIe-EC-HIB2-x4) is a PCIe x4 ExpressCard/34 adapter that adds high-speed PCI Express (PCIe) expansion capabilities to laptops. The PCIe cable port provides PCIe x4 connectivity to PCIe x4 and x1 external devices or expansion chassis with standard add-in board capability.

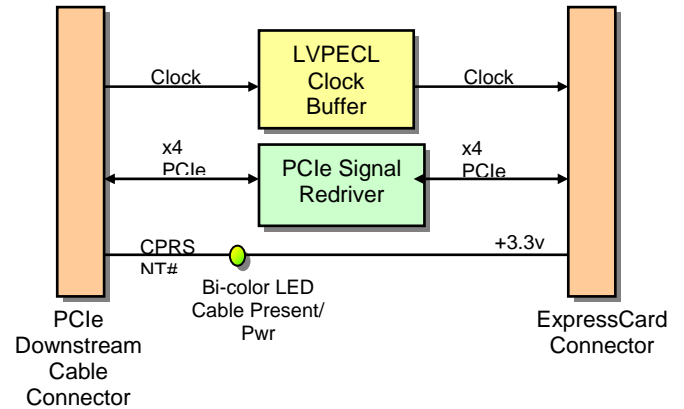
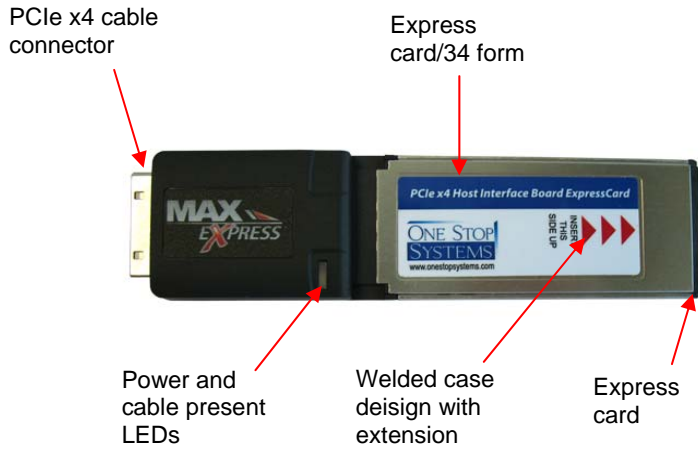

### 2.b. Target cable adapter

The PCIe x4 target adapter installs into an OSS 2-slot backplane and extends the PCI express bus to a single I/O board.

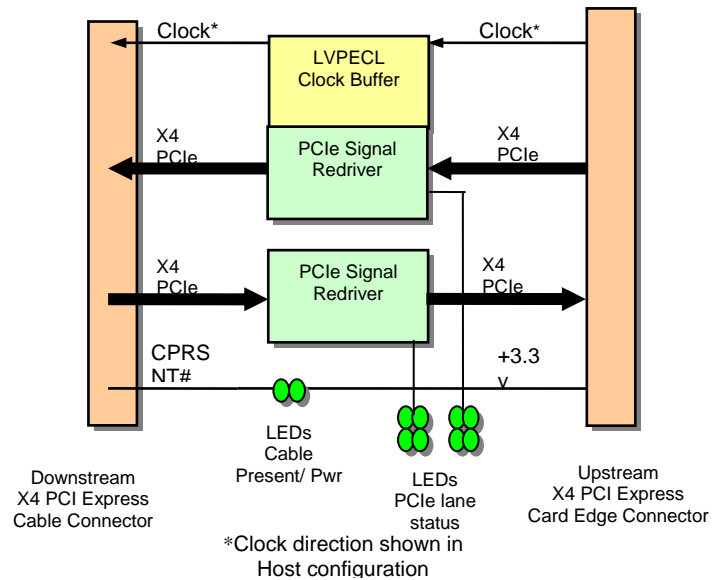
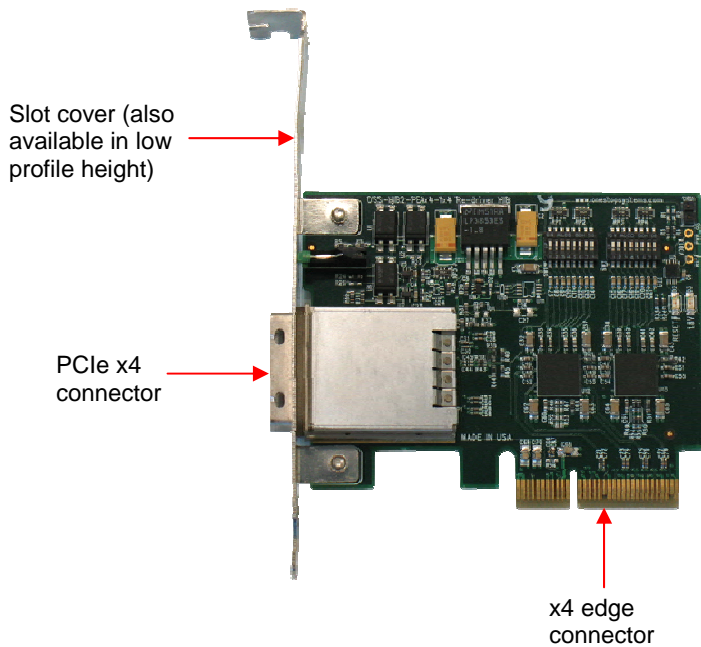

## 2.c. Express Card Specifications

Electrical/Mechanical Specifications	
Form Factor:	ExpressCard/34
Dimensions (H x L):	1.34 x 5.01 inches (34 x 127.3mm)
External Connectors:	One PCIe x4 cable connector
Board Indicators:	Power On / Cable Present LEDs
Power Consumption (designed to meet the following conditions)	
	3W typical, 3.3V@1A
Operating Environment (designed to meet the following conditions)	
Temperature Range:	0° to 55°C (32° to 131°F)
Relative Humidity:	10 to 90% non-condensing
Shock:	30g acceleration peak (11ms pulse) no cable connected
Vibration:	5-17 Hz 0.5" double amplitude displacement; 7-2000Hz, 1.5g acceleration.
Redriver	
Pericom PIEQX4401	
Agency Compliance Designed to meet, but not tested	
	UL60950, FCC Class B, CE safety and emissions

## 2.d. Target Adapter Specifications

Electrical/Mechanical Specifications	
Form Factor:	PCIe x4 add-in card
Dimensions (H x L):	2.713 x 3.354" (68 x 86mm)
Front Panel Connectors:	One PCIe x4 cable connector
Power Consumption (designed to meet the following conditions) 3.75W typical, 3.3@1.3A	
Operating Environment (designed to meet the following conditions)	
Temperature Range:	0° to 50°C (32° to 122°F)
Relative Humidity:	10 to 90% non-condensing
Shock:	30g acceleration peak (11ms pulse)
Vibration:	5-17 Hz 0.5" double amplitude displacement; 7-2000Hz, 1.5g acceleration.
Redriver: Pericom PI2EQX4402	
Agency Compliance: UL60950.FCC Class B, CE safety and emissions	

## 2.e. OSS 2-slot backplane

The 2-slot backplane can be installed in a separate enclosure to support the target adapter and an I/O card.  
Note: See section 4 technical information for slot pin outs.

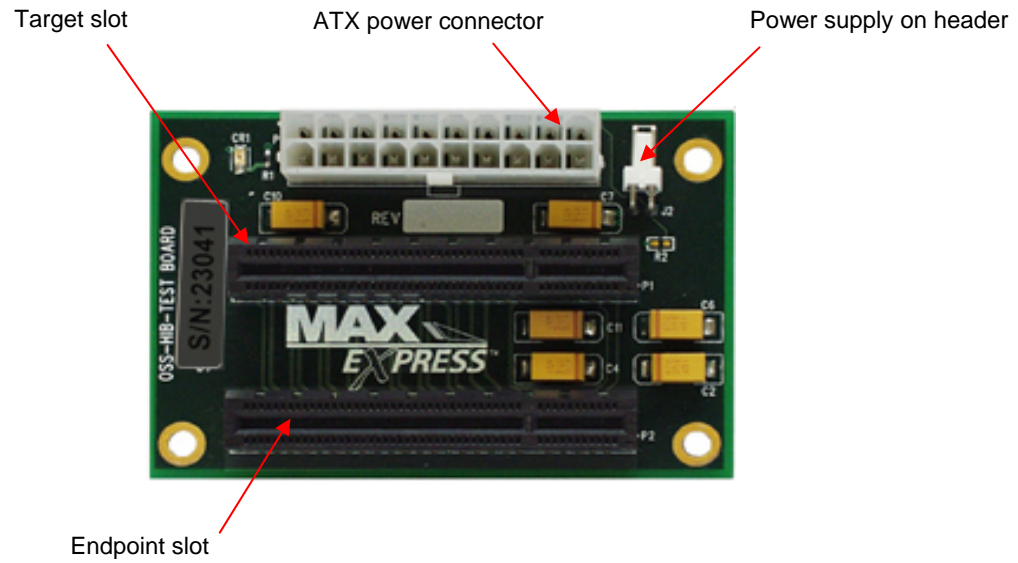

# 3. Installation Instructions

## 3.a. Installing the adapter kit:

1. Choose an empty ExpressCard slot. The card may be installed in any ExpressCard/ 34 (single wide) or ExpressCard/54 (double wide) slot.
2. Remove the plastic filler plate (if installed) from the ExpressCard slot and guide the card into the desired slot following the manufacturer's instructions.

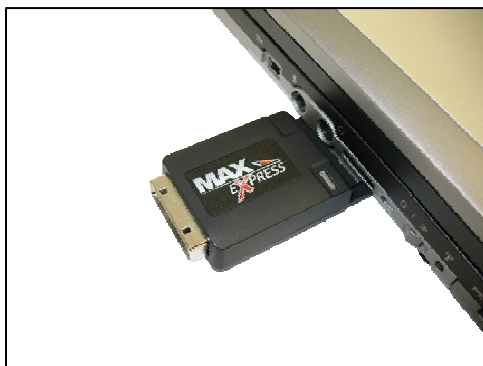

3. Attach the cable by first pulling back on the retractor ring. With the keyed slot aligned with the key ridge on the ExpressCard Cable Adapter, insert the cable connector into the cable port connector on the board until the cable locks in place.

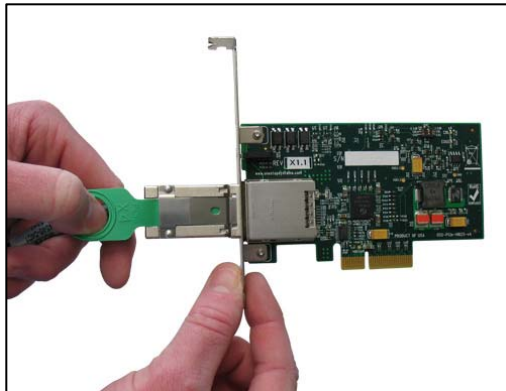

4. The connectors on either end of the PCIe x4 cable are identical. Each connector is equipped with a retractor to allow the connector to be locked into place.

## 3.b. When using with the 2-slot Backplane:

- 1) Insert the target cable adapter into the PCIe slot closest to the white ATX power connector, labeled TARGET on the 2-slot backplane.
- 2) Connect the 2-slot backplane to an ATX power supply separate from the host system power supply. Note: Sometimes an external load is necessary for ATX power supplies to regulate properly. (i.e. – connecting hard drive power)
- 3) Insert the PCI add-in board in the I/O slot of the 2-slot backplane.
- 4) Connect the PCIe cable to both cable adapters.

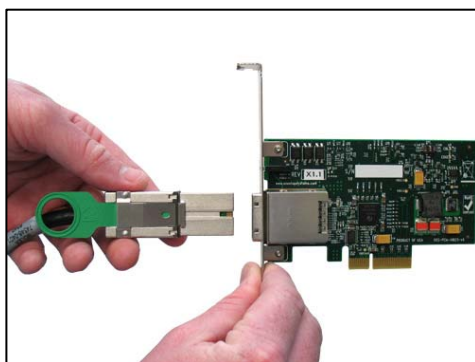

- 5) Power up the power supply to the 2-slot backplane. The 3V aux LED will light. NOTE: THE POWER SUPPLY AND 2-SLOT BACKPLANE WILL NOT POWER UP AT THIS TIME.
- 6) Power up the host system. The power and cable LEDs on the cable adapters will light. This powers up the two slot backplane.
- 7) The I/O board will start automatically.

### 3.c. When using with any third party I/O device:

- 1) Install the downstream board in the appropriate PCIe slot.
- 2) Connect the external power source (separate from the host system power supply) to the downstream device if necessary.
- 3) Connect the PCIe cable to both the upstream express card and the downstream device.

### 3.d. Removing PCIe cable:

- 1) To remove PCIe cable pull back on green thumb tab to release metal pins and gently separate.

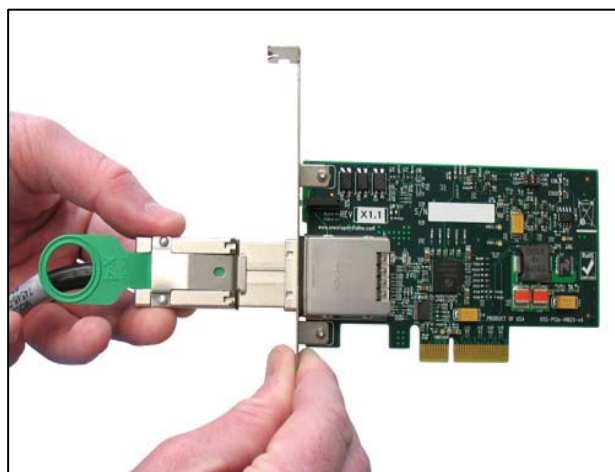
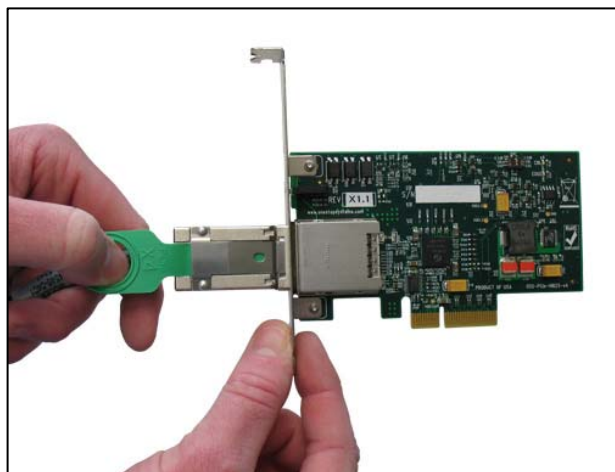

### 3.e. Removing your ExpressCard cable adapter:

1. Pull back on the retractor ring to release the locking mechanism and remove the cable from the external cable connector on the ExpressCard cable adapter.
2. Remove the adapter from the slot.

# 4. Technical Information

## 4.a. Redriver Settings

Table 1

2	3	4	Equalization
0	0	0	No Equalization
0	0	1	1.5db @ 1.25 GHz
0	1	0	2.5db @ 1.25 GHz
0	1	1	3.5db @ 1.25 GHz
1	0	0	4.5db @ 1.25 GHz
1	0	1	5.5db @ 1.25 GHz
1	1	0	5.5db @ 1.25 GHz
1	1	1	7.5db @ 1.25 GHz

Table 2

5	6	Swing
0	0	1x
0	1	0.8x
1	0	1.2x
1	1	1.4x

Table 3

7	8	De-emphasis
0	0	0db
0	1	-2.5db
1	0	-3.5db
1	1	-4.5db

## 4.b. Host cable adapter LEDs

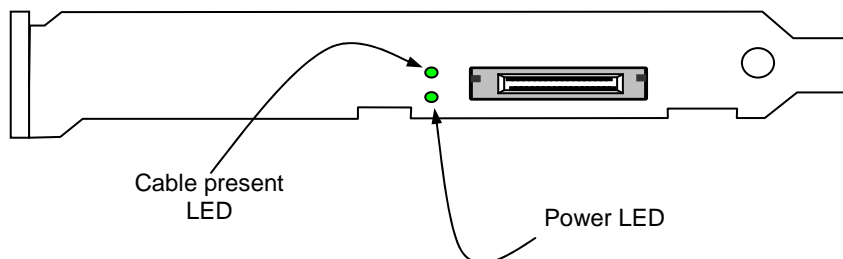
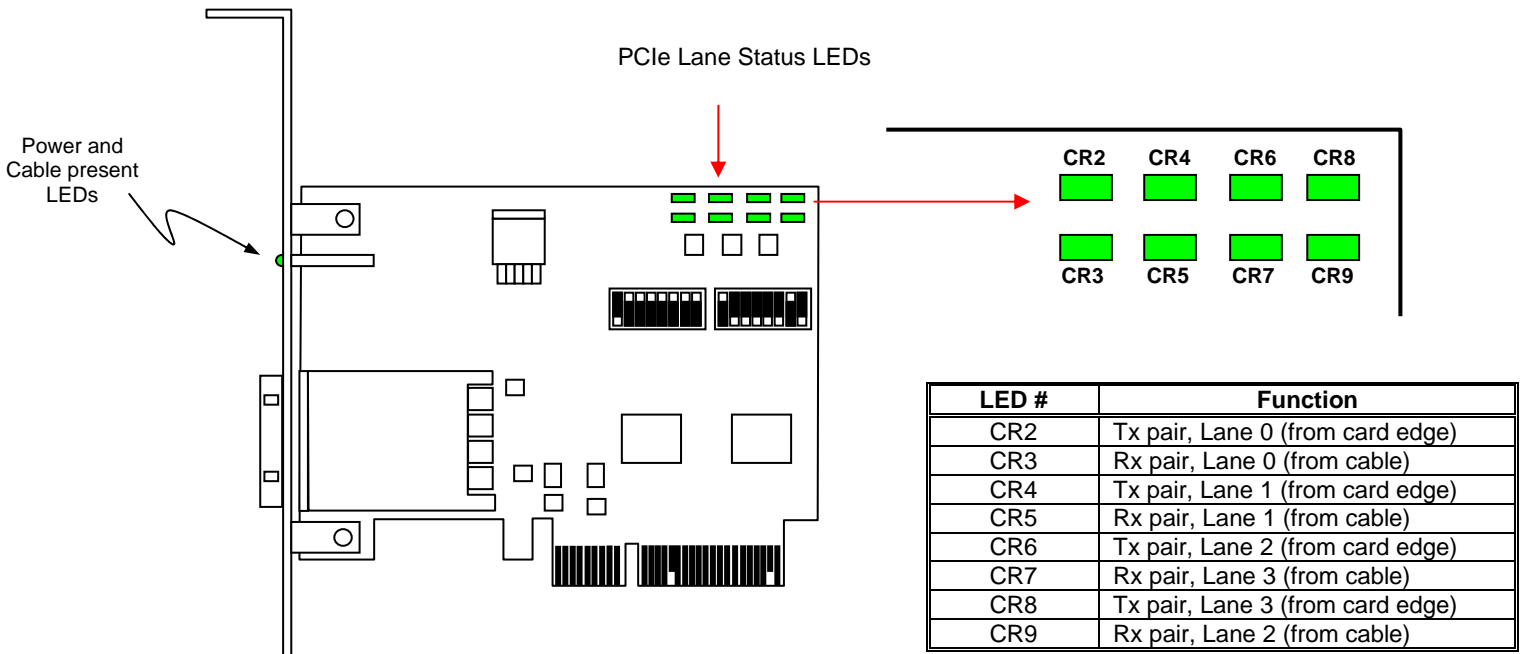

## 4.c. Pin Assignments

### Host adapter card connectors PCIe x4 Card Edge Connector

- The pins are numbered as shown with side A on the top of the centerline on the solder side of the board and side B on the bottom of the centerline on the component side of the board.
- The PCIe interface pins PETpx, PETnx, PERpx, and PERnx are named with the following convention: “PE” stands for PCIe high speed, “T” for Transmitter, “R” for Receiver, “p” for positive (+), and “n” for negative (-).
- Note that adjacent differential pairs are separated by two ground pins to manage the connector crosstalk.

### Pin-out for the PCIe x4 Card Edge Connector on the Host Cable Adapter

Pin #	Side B		Side A	
	Name	Description	Name	Description
1	N/C	N/C	PRSNT1#	Hot-Plug presence detect
2	N/C	N/C	N/C	N/C
3	N/C	N/C	N/C	N/C
4	GND	Ground	GND	Ground
5	NC	N/C	N/C	Not connected
6	N/C	N/C	JTAG3	TDI (Test Data Input)
7	GND	Ground	JTAG4	TDO (Test Data Output)
8	+3.3V	3.3 V power	N/C	Not connected
9	N/C	Not connected	N/C	Not connected
10	3.3Vaux	3.3 V auxiliary power	+3.3V	3.3 V power
11	N/C	N/C	PERST#	Fundamental reset
<b>Mechanical key</b>				
12	RSVD	Reserved	GND	Ground
13	GND	Ground	REFCLK+	Reference clock (differential pair)
14	PETp0	Transmitter differential pair, Lane 0	REFCLK	
15	PETn0		GND	Ground
16	GND	Ground	PERp0	Receiver differential pair, Lane 0
17	PRSNT2#	Hot-Plug presence detect	PERn0	
18	GND	Ground	GND	Ground
19	PETp1	Transmitter differential pair, Lane 1	RSVD	Reserved
20	PETn1		GND	Ground
21	GND	Ground	PERp1	Receiver differential pair, Lane 1
22	GND	Ground	PERn1	
23	PETp2	Transmitter differential pair, Lane 2	GND	Ground
24	PETn2		GND	Ground
25	GND	Ground	PERp2	Receiver differential pair, Lane 2
26	GND	Ground	PERn2	
27	PETp3	Transmitter differential pair, Lane 3	GND	Ground
28	PETn3		GND	Ground
29	GND	Ground	PERp3	Receiver differential pair, Lane 3
30	RSVD	Reserved	PERn3	
31	PRSNT2#	Hot-Plug presence detect	GND	Ground
32	GND	Ground	RSVD	Reserved

**Notes:**

1. Optional signals that are not implemented are left as no connects on the board side connector.
2. Reserved signals are no connects on the board side connector.
3. Although support of CWAKE# is optional from the board side connector perspective, an allocated wire is mandated for the cable assembly.
4. Board side pin-outs on both sides of the Link are identical. The cable assembly incorporates a null modem for the PCIe transmit and receive pairs.

**4.d. PCI Express x4 Connector Pin Assignment**

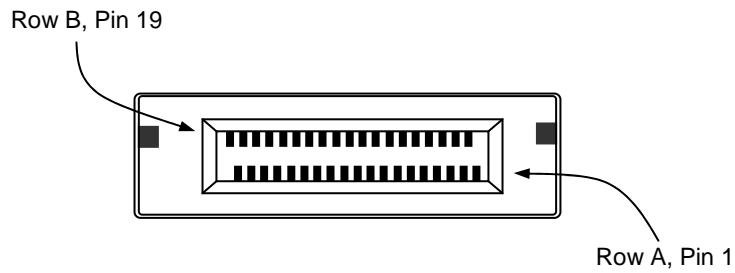

#### 4.e. Pin-out for the PCIe x4 Cable

Pin #	Cable Side 1		Cable Side 2	Pin #
A1 A4 A7 A10 A13 A16 B1 B4 B7 B10 B13	GND	Drain Wires	GND	A1 A4 A7 A10 A13 A16 B1 B4 B7 B10 B13
A2	PETp0	Differential Pair	PERp0	B2
A3	PETn0		PERn0	B3
A5	PETp1	Differential Pair	PERp1	B5
A6	PETn1		PERn1	B6

Pin #	Cable Side 1		Cable Side 2	Pin #
A8	PETp2	Differential Pair	PERp2	B8
A9	PETn2		PERn2	B9
A11	PETp3	Differential Pair	PERp3	B11
A12	PETn3		PERn3	B12
A14	CREFCLK+	Differential Pair	CREFCLK+	A14
A15	CREFCLK-		CREFCLK-	A15
A17	SB_RTN	Hook-up Wire	SB_RTN	A17
A18	CPRSNT#	Hook-up Wire	CPRSNT#	A18
A19	CPWRON	Hook-up Wire	CPWRON	A19
B2	PERp0	Differential Pair	PETp0	A2
B3	PERn0		PETn0	A3
B5	PERp1	Differential Pair	PETp1	A5
B6	PERn1		PETn1	A6
B8	PERp2	Differential Pair	PETp2	A8
B9	PERn2		PETn2	A9
B11	PERp3	Differential Pair	PETp3	A11
B12	PERn3		PETn3	A12
B14	PWR	NC	PWR	B14
B15	PWR	NC	PWR	B15
B16	PWR_RTN	NC	PWR_RTN	B16
B17	PWR_RTN	NC	PWR_RTN	B17
B18	CWAKE#	Hook-up Wire	CWAKE#	B18
B19	CPERST#	Hook-up Wire	CPERST#	B19
Backshell	Chassis Ground	Overall Cable Braid	Chassis Ground	Backshell

#### 4.f. Signal Descriptions

PETp(x)	PCI Express Transmit Positive signal of (x) pair.
PETn(x)	PCI Express Transmit Negative signal of (x) pair.
PERp(x)	PCI Express Receive Positive signal of (x) pair.
PERn(x)	PCI Express Receive Negative signal of (x) pair.
CREFCLK+/-	Cable REFerence CLock: Provides a reference clock from the host system to the remote system.
SB_RTN	Side Band ReTurN: return path for single ended signals from remote systems.
CPRSNT#	Cable PReSeNT: Indicates the presence of a device beyond the cable.
PWR	PoWeR: Provides local power for in-cable redriver circuits. Only needed on long cables. (Power does not go across the cable.)
PWR_RTN	PoWeR ReTurN: Provides local power return path for PWR pins.
CWAKE#	Cable WAKE
CPERST#	Cable PCI Express Reset

# 5. Ordering Information

## **OSS-KIT-EXP-500**

PCIe x4 expansion kit includes a PCIe x4 Gen 1 Express card, a PCIe x4 target cable adapter, and a PCIe x4 2M cable.