

## *IPsec and SSI security offload PMC Module*

*OSS-SecurePMC*

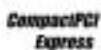

[www.onestopsystems.com](http://www.onestopsystems.com)

Phone 877-438-2724 • Fax 760-466-1678 • [sales@onestopsystems.com](mailto:sales@onestopsystems.com)

# Description

The OSS-SecurePMC is a PMC module for offloading Security Encryption processing. This design facilitates a computer system to perform encryption/decryption of data sessions using a Cavium CN1010 Nitrox Lite device without burdening the main processor with this computational intensive task.

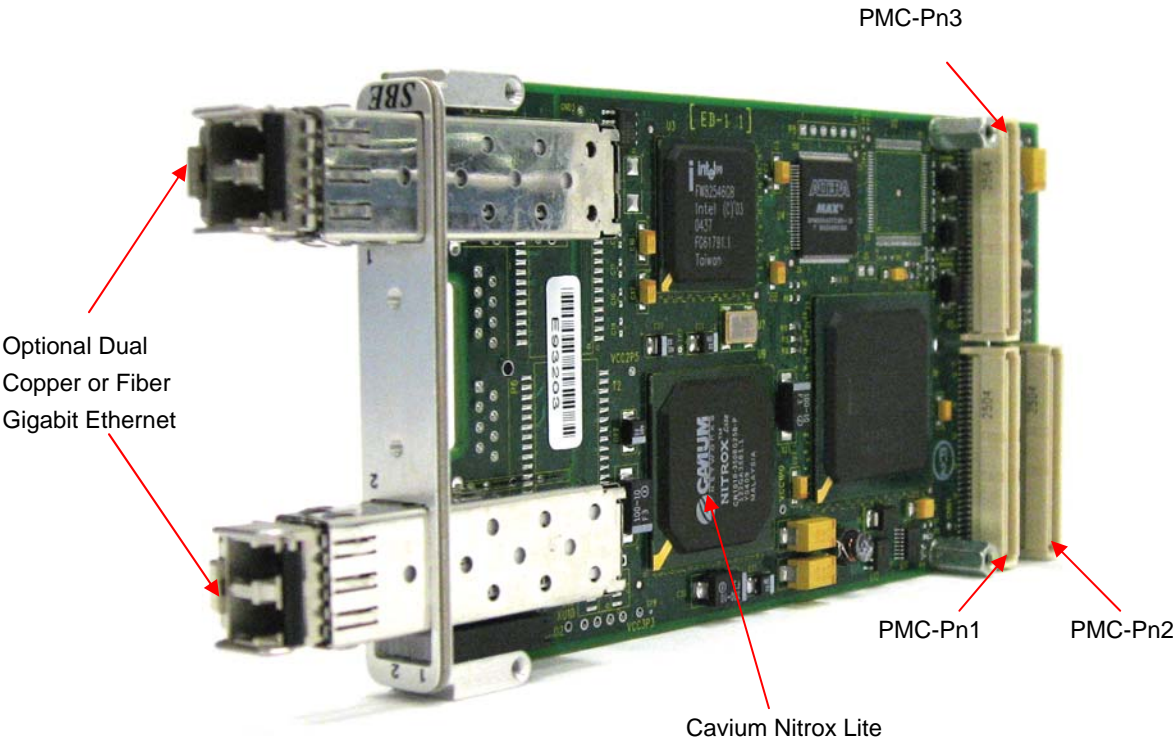
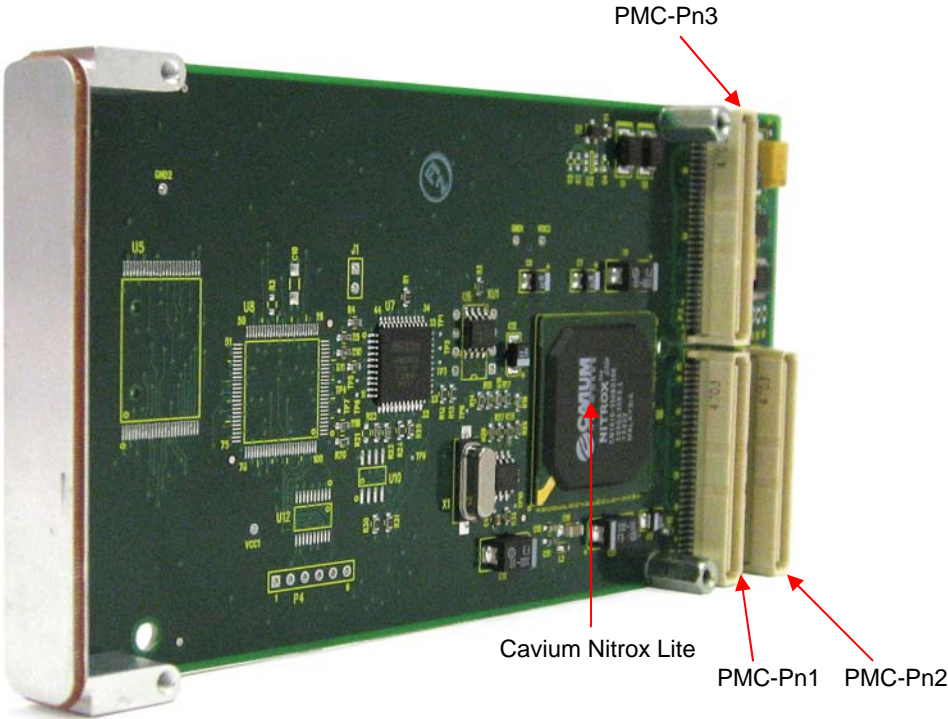

## Initial Set-Up

### Unpacking Instructions

1. If the carton is damaged when you receive it, request that the carrier's agent be present when you unpack and inspect the equipment.
2. After unpacking, verify that all items listed in the packing list are present.
3. Inspect the equipment for shipping damage.
4. Save all packing material for storage or return shipment of the equipment.
5. For repairs or replacement of equipment damaged during shipment, contact One Stop Systems, Inc. to obtain a Return Materials Authorization (RMA) number and further shipping instructions.

### Installation and Removal

1. Power down the host system.
2. Open the chassis according to your system documentation.
3. Let the power supply cool down, if necessary.
4. Remove the host board from the system.
5. Remove the OSS-SecurePMC from the protective bag, observing proper ESD safety procedures.

### Installing the OSS-SecurePMC:

1. Carefully slide the OSS-SecurePMC into an available peripheral board position on the desired carrier card, ensuring the front bezel is inserted properly into the carrier card's front panel opening. Check that the board is aligned properly on the bezel, connectors, and standoffs.
2. Completely insert the board until the connectors lock into place.
3. Insert and tighten standoff screws to secure the OSS-SecurePMC in place

#### Installation Diagram

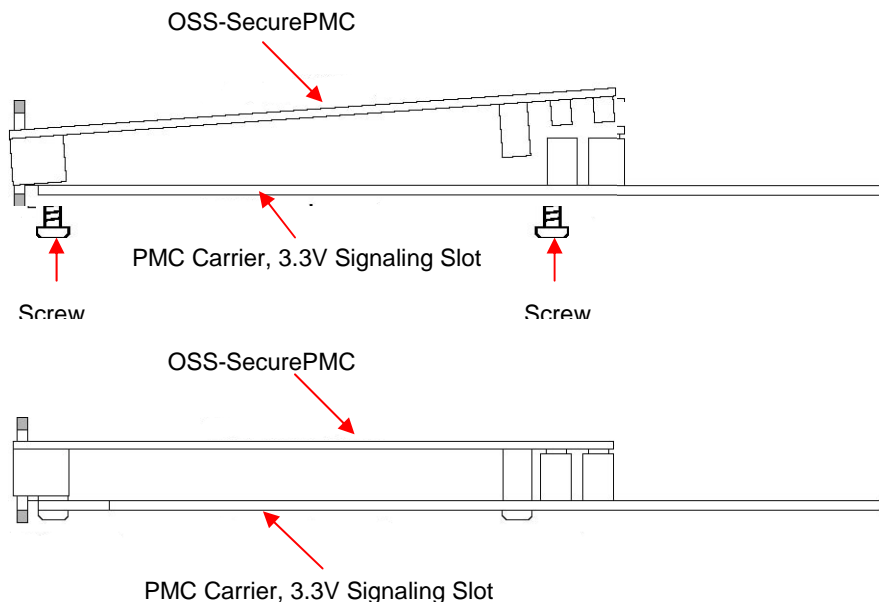

## Specifications

Electrical/Mechanical Specifications	
Form Factor:	64 bit, 33/66 MHz PMC interface (PCI Rev 2.2) using 3.3V signaling
Dimensions (H x L):	5.86 x 2.91 inches (148.8 x 73.9mm)
Front Panel Connectors:	Optional Dual Copper or Fiber Ethernet Connectors
LEDs:	Voltage indicator and reset LEDs on rear of the board
Power Consumption (designed to meet the following conditions)	
	2.0W maximum (3.3V @.24A, 5V@.24A)
Operating Environment (designed to meet the following conditions)	
Temperature Range:	0° to 55°C (32° to 136°F)
Relative Humidity:	10 to 90% non-condensing
Shock:	30g acceleration peak (11ms pulse)
Vibration:	5-17 Hz 0.5" double amplitude displacement; 7-2000Hz, 1.5g acceleration.
Agency Compliance Designed to meet, but not tested	
	UL 60950, FCC Class B, CE Mark, NEBS, VCCI

## Block Diagram

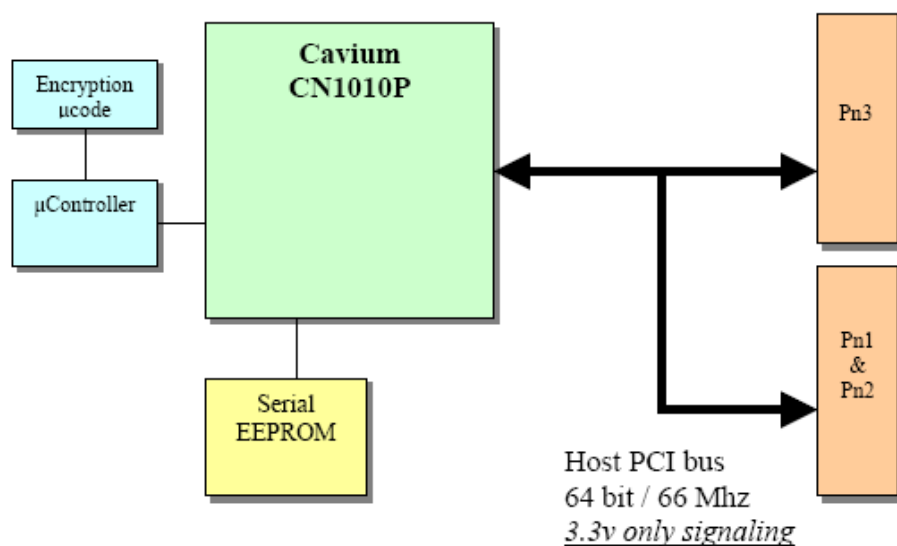

## Security Offload Engine

The Cavium CN1010 Nitrox Lite is a multi core encryption accelerator used to offload security processing from the CPU. The Nitrox Lite has the ability to process IPsec, IKE, and SSL protocols, and multiple security algorithms, e.g. RSA, DiffieHellman, DES, 3DES, MD5, SHA-1, HMAC-MD5, etc. This implementation uses FreeS/WAN and OpenSSL, and TurboIPsec. More information about the Cavium Nitrox Lite device can be found at [www.cavium.com](http://www.cavium.com).

## PMC Voltage Keying

The Cavium CN1010 PCI interface is capable of operating **only in 3.3-volt signaling** environments. Therefore, only the 3.3v-keying hole is provided on the PCB. When installing the card on a host, the voltage-coding key (on the host) must be installed in accordance with the host requirements. Note that 66MHz operation is only defined for 3.3-volt signaling.

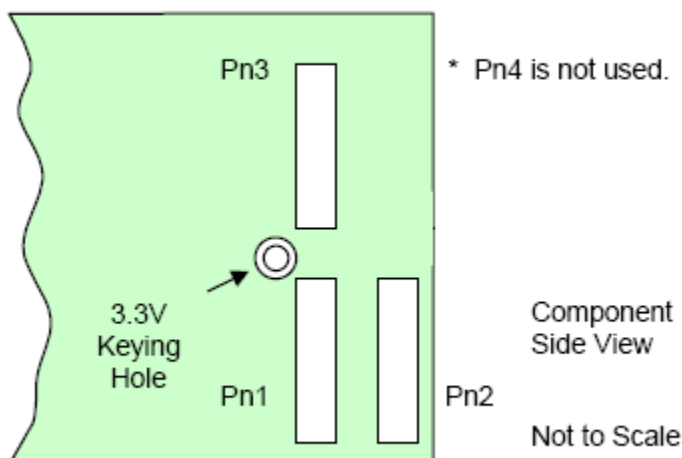

Note about PCI adapters: You may mount the OSS-SecurePMC on either a 32-bit adapter or a 64-bit adaptor (such as the SBE adaptPCI-PMC). However, do not mount a 64-bit card (such as the securePMC-L) on a 32-bit adapter, and then install it in a 64-bit PCI slot. This violates the PCI specification for the signals REQ64# and ACK64#, and causes indeterminate results.

## LEDs

Two voltage indicator LEDs are mounted on the back of the board for visibility when the board is mounted on a carrier. The LEDs are CR2 (1.0v), and CR4 (3.3v). The LED indications are red (voltage bad) or green (voltage good).

On the back of the OSS-SecurePMC card is a LED indicating the reset state of the card. CR3 is a yellow LED indicating reset (on) or not in reset (off).

## Busmode Pins

Since OSS-SecurePMC supports only the PCI bus protocol at the PMC connectors, the BUSMODE1# pin is asserted LOW for two reasons only; (1) to indicate its presence to the host, and (2) to indicate that it is capable of performing PCI Bus protocol (see Table below). The OSS-SecurePMC responds within ten PCI clock cycles after detecting the state of BUSMODE[4:2]# pins.

BUSMODE[4:2]# state (input)	Mode	BUSMODE1# output state	Response explanation
000	“Card Present” test.	0	“Card Present” mode. No bus protocol is used and card is held in reset
001	Return Card Present if PCI capable and uses PCI protocol.	0	Capable of performing PCI protocol.
All other states	-	1	Card held in reset.

## Reset

The board is in reset if any one of the following conditions is true:

- PCI reset is asserted.
- BUSMODE[4:2]# don't correspond to PCI protocol.
- 

If BUSMODE pins are not implemented properly on the host then the OSS-SecurePMC will not come out of reset. In such situations the CPLD may be modified to ignore the BUSMODE inputs.

## Subsystem ID

The OSS-SecurePMC is assigned subsystem ID 0x0810.

## CPLD

An EPM3032A CPLD from Altera is used to implement the LED control and reset functions. There are no Host accessible registers in the CPLD. There are 30 user I/O pins of which all but one are used.

## Clocks

The CN1010 requires a 50MHz clock, which is supplied by an on board crystal and PLL.

## Power

The OSS-SecurePMC requires both 5v and 3.3v from the host. Since this board is designed specifically for use in 66MHz systems, it can be assumed that the host will provide ample and clean 3.3v to the module

## Connectors

The OSS-SecurePMC uses Pn1, Pn2, and Pn3 connectors for 64-bit operation. Pn4 is not used.

Pn1 32-bit PCI				Pn2 32-bit PCI				Pn3 64-bit PCI			
Pin #	Name	Name	Pin #	Pin #	Name	Name	Pin #	Pin #	Name	Name	Pin #
1	TCK	-12V	2	1	+12V	TRST#	2	1	PCI-RSVD	Ground	2
3	Ground	INTA#	4	3	TMS	TDO	4	3	Ground	C/BE[7]#	4
5	INTB#	INTC#	6	5	TDI	Ground	6	5	C/BE[6]#	C/BE[5]#	6
7	BUSMODE1#	+5V	8	7	Ground	PCI-RSVD	8	7	C/BE[4]#	Ground	8
9	INTD#	PCI-RSVD	10	9	PCI-RSVD	PCI-RSVD	10	9	V(I/O)	PAR64	10
11	Ground	3.3Vaux	12	11	BUSMODE2#	+3.3V	12	11	AD[63]	AD[62]	12
13	CLK	Ground	14	13	RST#	BUSMODE3#	14	13	AD[61]	Ground	14
15	Ground	GNT#	16	15	+3.3V	BUSMODE4#	16	15	Ground	AD[60]	16
17	REQ#	+5V	18	17	PME#	Ground	18	17	AD[59]	AD[58]	18
19	V(I/O)	AD[31]	20	19	AD[30]	AD[29]	20	19	AD[57]	Ground	20
21	AD[28]	AD[27]	22	21	Ground	AD[26]	22	21	V(I/O)	AD[56]	22
23	AD[25]	Ground	24	23	AD[24]	+3.3V	24	23	AD[55]	AD[56]	24
25	Ground	C/BE[3]#	26	25	IDSEL	AD[23]	26	25	AD[53]	Ground	26
27	AD[22]	AD[21]	28	27	+3.3V	AD[20]	28	27	Ground	AD[52]	28
29	AD[19]	+5V	30	29	AD[18]	Ground	30	29	AD[51]	AD[50]	30
31	V(I/O)	AD[17]	32	31	AD[16]	C/BE[2]#	32	31	AD[49]	Ground	32
33	FRAME#	Ground	34	33	Ground	PMC-RSVD	34	33	Ground	AD[48]	34
35	Ground	IRDY#	36	35	TRDY#	+3.3V	36	35	AD[47]	AD[46]	36
37	DEVSEL#	+5V	38	37	Ground	STOP#	38	37	AD[45]	Ground	38
39	Ground	LOCK#	40	39	PERR#	Ground	40	39	V(I/O)	AD[44]	40
41	PCI-RSDV*	PCI-RSVD	42	41	+3.3V	SERR#	42	41	AD[43]	AD[42]	42
43	PAR	Ground	44	43	C/BE[1]#	Ground	44	43	AD[41]	Ground	44
45	V(I/O)	AD[15]	46	45	AD[14]	AD[13]	46	45	Ground	AD[40]	46
47	AD[12]	AD[11]	48	47	M66EN	AD[10]	48	47	AD[39]	AD[38]	48
49	AD[09]	+5V	50	49	AD[08]	+3.3V	50	49	AD[37]	Ground	50
51	Ground	C/BE[0]#	52	51	AD[07]	PMC-RSVD	52	51	Ground	AD[36]	52
53	AD[06]	AD[05]	54	53	+3.3V	PMC-RSVD	54	53	AD[35]	AD[34]	54
55	AD[04]	Ground	56	55	PMC-RSVD	Ground	56	55	AD[33]	Ground	56
57	V(I/O)	AD[03]	58	57	PMC-RSVD	PMC-RSVD	58	57	V(I/O)	AD[32]	58
59	AD[02]	AD[01]	60	59	Ground	PMC-RSVD	60	59	PCI-RSVD	PCI-RSVD	60
61	AD[00]	+5V	62	61	ACK64#	+3.3V	62	61	PCI-RSVD	Ground	62
63	Ground	REQ64#	64	63	Ground	PMC-RSVD	64	63	Ground	PCI-RSVD	64